

Use of a Continuously Variable Transmission to Optimize Performance and Efficiency of Two-Wheeled Light Electric Vehicles (LEV)

Carter, Jeremy¹, McDaniel, Loren², Vasiliotis, Christopher³

¹Fallbrook Technologies Inc., Cedar Park, Texas, USA – jcarter@fallbrooktech.com

²Formerly Fallbrook Technologies Inc., Cedar Park, Texas, USA

³Fallbrook Technologies Inc., Cedar Park, Texas, USA – cvasiliotis@fallbrooktech.com

EET-2007 European Ele-Drive Conference
Brussels, Belgium, May 30 – June 01, 2007

(Updated Test Data, March 2008)

Abstract

The powertrain of a simple electric vehicle is comprised of the power source (battery), electric drive (motor & controller), and power transmission device (sprockets, chain, gearing, etc.). Many electric vehicles operate in a direct-drive configuration, where the speed of the vehicle is directly linked to the speed of the drive motor (related by a fixed gear ratio from sprockets or other gearing). An electric vehicle powertrain is not unlike a conventional automotive internal combustion engine powertrain; that is, the individual components and complete system have different efficiencies and performance characteristics at different motor speeds and load conditions. If a continuously variable transmission (CVT) is used in an electric vehicle application, these efficiency and performance benefits at particular operational speeds and load conditions can be better utilized, thereby increasing overall vehicle performance. This paper quantifies the benefits of incorporating the NuVinci[®] Continuously Variable Planetary Transmission (CVP) into a light electric vehicle (LEV). The *NuVinci* CVP is a compact and high torque-density unit that uses planetary spheres to offer continuously variable speed ratio control in wide-ranging applications. When coupled with an advanced, yet economical control system to vary the speed ratio for optimal powertrain operation, the system shows benefits in overall vehicle performance. Analysis models show the benefits of the CVP in an LEV application, and the results were confirmed by functional testing of CVP-equipped LEV scooters that were compared to benchmark (fixed-gear ratio) stock vehicles.

Keywords: scooter, transmission, controller, hybrid, NEV

1 Introduction

Electric vehicles are becoming more popular around the world as battery prices decline and technology and performance advance. Factors such as high fuel costs and internal combustion engine emissions are making electric vehicles more attractive to customers looking for a cost-effective commuting option. However, electric

vehicle performance and range is often less than that of competitive gasoline-powered vehicles. Additionally, manufacturer claims for speed and range are often idealized, and not representative of real-world conditions.

If there is an “enabling technology” that can be applied in order to increase performance and range, electric vehicles could begin to compete with gasoline-powered vehicles, providing quiet,

clean, and efficient transportation for commuters worldwide. By incorporating a *NuVinci* transmission into the rear wheel of a standard electric scooter, Fallbrook Technologies is exploring the advantages of a continuously variable drivetrain in electric vehicle applications.

2 Background

The powertrain of a simple electric vehicle is comprised of the power source (battery), electric drive (motor & controller), and power transmission device (sprockets, chain, gearing, etc.). The electric motor has an efficiency that varies as a function of operating speed and load, and the battery discharge time varies as a function of current draw (see Figures 1 and 2 for representative data [1], [2]).

A majority of light electric vehicles (LEV) utilize a direct-drive configuration where the vehicle speed is tied directly to the motor speed by a fixed gear ratio. This is a very simple configuration, and no variable ratios are implemented, usually at the expense of some performance and efficiency.

LEV drive cycles typically involve numerous stops and starts, uneven terrain, and variable wind resistance. Powertrains with continuously variable transmissions (CVT) can benefit vehicles that operate over these dynamic speed and load conditions by allowing the motor to operate closer to its peak power or peak efficiency over a broad range of a given duty cycle. Additionally, a CVT changes the effective inertia seen at the motor to increase acceleration of the vehicle.

The *NuVinci* Continuously Variable Planetary (CVP) transmission and control system provides smooth, seamless shifting across the full gear ratio range. There is no jolt and no loss of momentum during shift events. In addition, since there are no fixed gear ratios, the system is able to control component speeds precisely, allowing them to operate exactly at their optimal speed for the desired performance.

3 CVP Overview

Figure 3 shows a simplified cross section of the *NuVinci* CVP [3]. A bank of balls (planets) is placed in a circular array around a central idler and in contact with separate input and output discs (or traction rings).

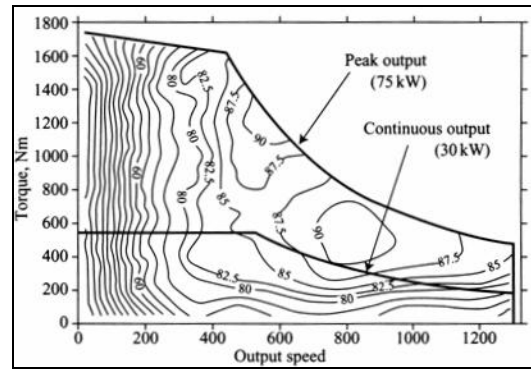

Figure 1: Example Motor Efficiency & Output Characteristics [1]

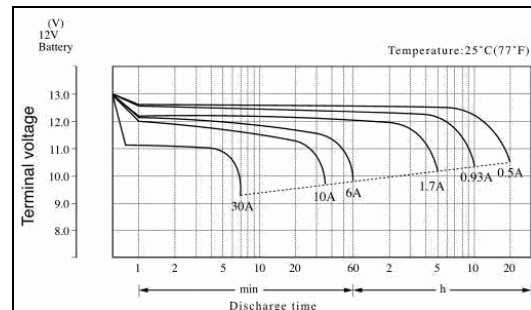

Figure 2: Example Battery Discharge Characteristics [2]

Power comes through the input disc and is transmitted to the balls, then to the output disc via traction at the rolling contact interface between the balls and discs.

Figure 4 presents the system kinematics, where r_i is the contact radius of the input contact, and r_o is the contact radius at the output contact. The speed ratio is defined by the tilt angle of the ball axis, which changes the ratio of r_i to r_o , and thus the speed ratio [4]. The result is the ability to sweep the transmission through the entire ratio range smoothly, while in motion or stopped.

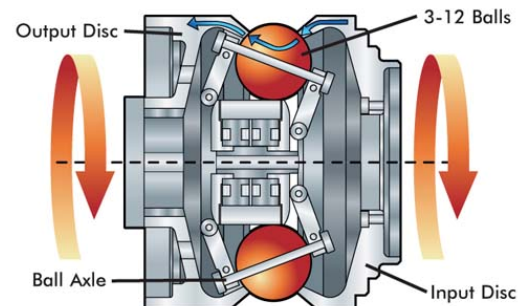

Figure 3: *NuVinci* CVP geometric configuration [3]

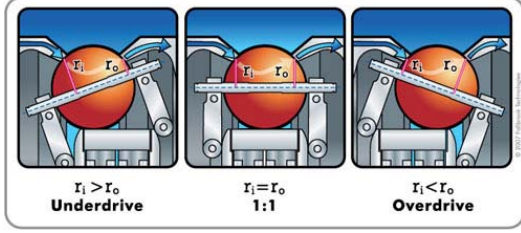

Figure 4: NuVinci Ratio Control

Figure 5 illustrates the orientation of the transmission components for a NuVinci bicycle CVP that is currently in production.

Figure 6 represents the NuVinci CVP in an LEV application. The CVP is integrated into the rear wheel of the vehicle, and ratio is controlled automatically via a shift actuator and control system.



Figure 5: NuVinci Bicycle Planetary Arrangement

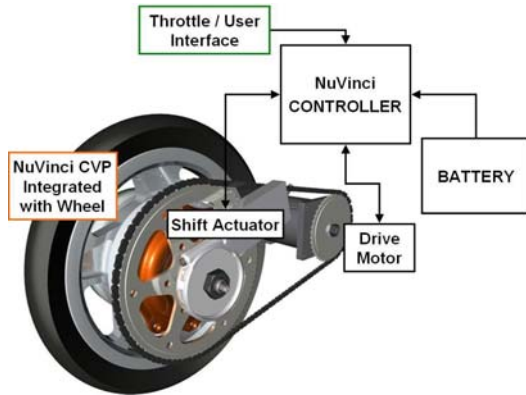

Figure 6: NuVinci LEV Transmission Configuration

3.1 Shift Control

The LEV application of the NuVinci CVP uses a shift actuator and intelligent control system to allow continuous and optimized shifting. The vehicle is equipped with a controller that monitors system operating parameters (e.g. battery current, wheel speed, shift position, etc.) to control the transmission and motor in closed loop control.

The system is configured to optimize motor speed, battery current, and transmission ratio based on motor and transmission efficiency characteristics. Effectively, by measuring vehicle speed and current draw, the NuVinci CVP can be utilized to optimize performance or range at the user's discretion.

4 Simulation and Analysis

The LEV used for simulation and analysis is the Currie IZIP 1000 scooter, as documented in the "Testing" section of this paper. Basic vehicle dynamics equations can illustrate the possible performance advantages of a CVP added to this direct-drive LEV. The equation of longitudinal motion can be described by:

$$M_v a_v = F_t - F_f - F_w \quad (1)$$

where:

- M_v = mass of the vehicle & rider
- a_v = acceleration of the vehicle & rider
- F_t = tractive force at the drive wheel
- F_f = force due to total road loads
- F_w = force due to aerodynamic drag

Equations for the forces above can be stated as:

$$F_t = \frac{(T_m - I_{eq_m} \alpha_m) i_o i_{cvp} \eta_{cvp}}{r_d} \quad (2)$$

$$F_f = M_v g (f_r + slope) \quad (3)$$

$$F_w = \frac{1}{2} \rho C_d A_f v^2 \quad (4)$$

where:

- T_m = torque output of the motor
- I_{eq_m} = equivalent reflected inertia at motor
- α_m = angular acceleration of the motor
- i_o = gear ratio of motor to CVP (motor speed / CVP input speed)
- i_{cvp} = gear ratio of CVP (CVP input speed / CVP output speed)
- η_{cvp} = efficiency of CVP
- r_d = effective radius of the tire
- g = acceleration due to gravity
- f_r = rolling resistance coefficient
- $slope$ = elevation divided by distance
- ρ = density of air
- C_d = aerodynamic drag coefficient
- A_f = frontal area of vehicle & rider
- v = velocity of vehicle & rider

The equivalent reflected inertia at the motor shaft is determined to be:

$$I_{eq_m} = I_m + \frac{I_w}{i_o^2 i_{cvp}^2} \quad (5)$$

where:

- I_m = rotational inertia of the motor
- I_w = rotational inertia of the wheel

These basic equations provide a framework to determine acceleration, hill climb ability, and maximum speed improvements possible with a CVP-equipped Currie IZIP 1000 scooter.

4.1 Acceleration

For vehicle launch, both initial speed and aerodynamic drag are zero. At this instant, the acceleration of the vehicle is determined from Equations 1 through 4 and is:

$$a_v = \frac{(T_m - I_{eq_m} \alpha_m) i_o i_{cvp} \eta_{cvp}}{M_v r_d} - g f_r \quad (6)$$

Using values representative of the Currie IZIP 1000 scooter, it can be shown that initial launch acceleration (a_v) can be improved up to 45% by implementing a CVP into the system. Any improvements shown through this equation

assume that the vehicle is not traction limited, and that the acceleration is stable and controllable.

Further, Figure 7 shows that for a representative motor curve (similar to Figure 1), the CVP allows the motor to reach its peak power condition at a lower vehicle speed than with a fixed ratio configuration.

The CVP can also have a profound effect on reflected inertia at the motor shaft, as defined in equation 5. A higher gear ratio (more underdrive) reduces the rotational inertia reflected at the motor, and thus increases acceleration for a given torque. With the ability to modulate the equivalent inertia at the motor shaft, the CVP can be used to manage acceleration at all portions of the drive cycle. This leads to the topic of shift strategy, which is outside of the scope of this paper, but promises to greatly enhance performance with a continuously variable drivetrain.

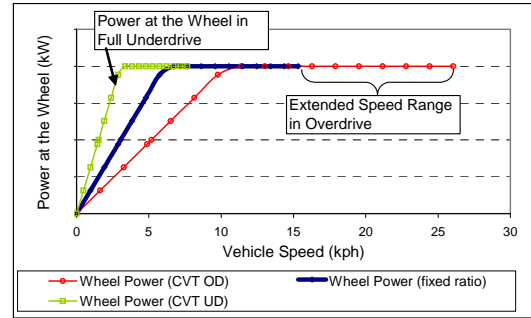

Figure 7: Power Delivered to the Wheel for a Fixed Ratio System vs. a CVP system

4.2 Hill Climb

A reasonable metric for hill climb capability can be defined as the maximum steady state speed that can be achieved on a given slope. Because this is a steady state metric, the acceleration component of equation 1 is zero, and we can determine the speed for a given slope by combining equations 1 through 4 and solving for steady state velocity:

$$v = \sqrt{\frac{2T_m i_o i_{cvp} \eta_{cvp} - M_v g (f_r + slope) r_d}{\rho_a C_d A_f r_d}} \quad (7)$$

Another metric of interest is the maximum slope the vehicle and rider can climb at a given velocity, which is simply solving equation 7 for steady state slope:

$$\text{slope} = \frac{T_m i_o i_{cvp} \eta_{cvt} - \frac{1}{2} \rho C_d A_f v^2 r_d}{M_v g r_d} - f_r \quad (8)$$

Using values representative of the Currie IZIP 1000 scooter, it can be shown that a CVP-equipped scooter can theoretically obtain a 69% increase in steady state velocity up a given slope. It should be noted that this is due to the fact that in the stock scooter the motor speed drops below its base speed, where it delivers less power. It can also be shown that the maximum slope the vehicle and rider can climb is increased by 45% with a CVP.

Additionally, steady state torque at the rear wheel (T_w) can be defined from Equation 2 as:

$$T_w = F_t r_d = T_m i_o i_{cvt} \eta_{cvt} \quad (9)$$

If we apply a generic torque curve for a typical controlled, brushed DC motor, as commonly used in LEV systems, and apply the CVP ratio in equation 9, we can define the effect that the CVP has to increase the overall operating range of the vehicle. This is shown for a generic motor curve in Figure 8.

Further, in Figure 8 we see that in underdrive the CVP increases the torque delivered to ground and increases the vehicle's hill climb capability.

4.3 Maximum Speed

Maximum speed is defined as the maximum speed a vehicle and rider can reach at steady state, with no grade. Similar to the hill climb, acceleration is zero at this condition and there is no dependence on system inertia.

There are two basic scenarios that can define the maximum possible speed for an electric vehicle. If the motor can freely spin to its maximum speed, the vehicle is said to be *motor speed-limited*. If the motor cannot reach its maximum speed because of road load and aerodynamic forces, the vehicle is said to be *power-limited*.

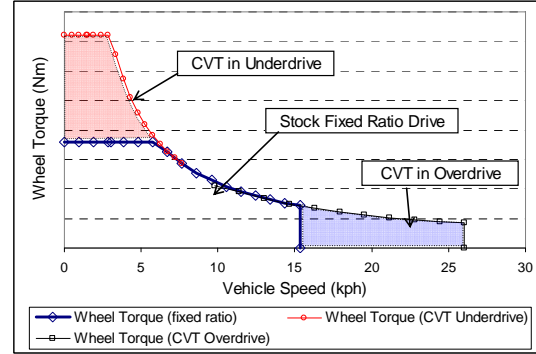

Figure 8: Changes in Torque Curve at the Wheel with a CVP

If the maximum speed of a vehicle is motor speed-limited, the vehicle maximum speed can be increased by adding a CVP, as shown in the overdrive region in Figure 8. The vehicle can be geared such that, at maximum speed, the tractive force at the wheel is completely opposed by the road loads and aerodynamic drag. This is also governed by equation 7 in the previous section.

The Currie IZIP 1000 scooter is motor speed-limited, and therefore benefits from the addition of the CVP. Using equation 7 with representative values for the Currie scooter, it can be shown that the vehicle maximum speed can be improved by up to 75%.

If the maximum speed of a vehicle is power-limited in a fixed ratio configuration, the addition of a CVP will not increase the top speed. The reason behind this is that the electric motor provides constant power beyond its base speed (as shown in Figure 7). A transmission does not add power to the system, so if the total road load and aerodynamic drag has matched the power limit of the vehicle, it will not accelerate further. It should be noted, however, that for the operating range of majority of light electric vehicles on the market today (e.g. scooters, NEV's, etc.), this is not the case.

4.4 Range

It is apparent that a CVP in an LEV application will be able to increase performance in many different categories, including launch acceleration, hill climb ability, and top speed. In order to improve operating range on a single battery charge, however, the system must take into account motor and transmission efficiency, as well as battery performance. The vehicle

control must take a “system level” approach to control all components to conditions that optimize overall system efficiency.

The operating range of an LEV is heavily dependent on the drive cycle (e.g. frequency and intensity of stops, starts, and elevation changes). For a preliminary analysis, a drive cycle was used that included no stops, four substantial elevation changes, and speeds ranging from 16 to 24 kph on the stock Currie IZIP 1000 scooter.

A dynamic simulation was created to model the performance of the 1000W scooter over the chosen drive cycle. The simulation included the following features:

- Dynamic permanent magnet DC motor model (including measured efficiency data)
- Dynamic CVP model (including measured efficiency data)
- Total road load and aerodynamic drag model
- Simplified battery model where voltage drops as a function of current draw
- Simplified current limiter that limits input power to motor

An algorithm was written to simulate ratio control for the CVP that would only shift the transmission when an efficiency improvement could be achieved. Otherwise, the CVP was kept at the ratio of peak efficiency.

The simulation with very simplistic control showed that for the given duty cycle, the CVP approximately matched the range performance of a stock scooter while still enabling improvements in hill climb, acceleration and top speed. With further controls tuning and a more urban drive cycle with stops and starts, it is reasonable to expect an improvement in operating range with the CVP.

5 Testing

To evaluate the impact of a CVP on an LEV, tests were conducted to benchmark the performance of an unmodified (stock) vehicle against a vehicle equipped with a *NuVinci* CVP and control system. The test vehicle for this program was the 2006 model Currie IZIP1000 36 volt scooter, shown in Figure 9. Both vehicles retained the stock motor (1000 Watts) and sprockets (15 and 90 tooth). Three control batteries were used for all tests.



Figure 9: CVP Enabled Currie IZIP 1000 Scooter

The *NuVinci* CVP was integrated into a new rear wheel design, which is compatible with the stock scooter frame assembly. The final production-intent wheel/CVP design is shown in Figure 10.



Figure 10: *NuVinci* CVP Housed in Rear Wheel

Tests were conducted with a data acquisition system fixed to the vehicle that included a data logger, supply battery, and various sensors and wiring. Five sets of tests were performed, including standing start acceleration, maximum speed, hill climb, maximum load up a grade, and range.

Acceleration and maximum speed tests were conducted from a standing start on flat asphalt, and used a prescribed start line and an infrared photogate for the finish at a distance of 0.2 km (1/8 mile). Recorded data was used to obtain acceleration times from 0-16 kph and 0-19 kph (0-10 mph and 0-12 mph), and the time to complete the distance. Top speed was measured in an independent test on flat asphalt

The hill climb benchmark was performed on a prescribed hill with subtly increasing grade over a fixed distance of 0.7 km (0.43 mile). Both scooters were able to climb this hill with an identical, representative load.

The maximum load up a grade was performed on a steeper hill than the hill climb benchmark. For this test, load was increased for each scooter until it was unable to ascend the grade continuously.

The maximum load each scooter could successfully ascend the grade was recorded.

Finally, the range test involved three different categories. Similar to the EPA drive cycles for automobiles, vehicle range will vary depending on the duty cycle. To determine the effects of the NuVinci CVP on different duty cycles, three range tests were derived: highway, city, and hill range. Over each range test, the vehicle started with a fully charged battery, and was operated continuously until the battery voltage dropped below 30.5 volts at a minimum stable speed.

Highway range involved typically higher speeds and very few stops and starts. The highway range was determined by operating the vehicle continuously over a 5.2 km (3.2 mile) loop. The course included a variety of grades and two stops and starts. The elevation profile and route for the highway range test are shown in Figures 11 and 13.

City range was intended to simulate an urban drive cycle with many starts and stops. Roughly every city block, the scooter was stopped completely and started again under full throttle, similar to a downtown commuting environment. The elevation profile for this course was flat.

Hill range was determined on the same hill from the hill climb benchmark, and was simply the distance each scooter could travel by ascending and descending the hill, for a loop length of 1.4 km (0.87 mile). The elevation profile and route for the Hill Range test are shown in Figures 12 and 13.

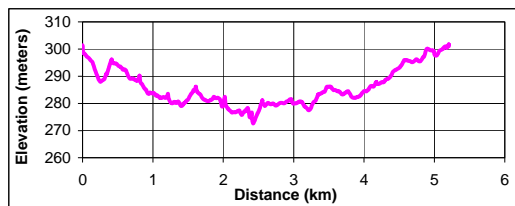

Figure 11: Highway Range Drive Profile, 5.2 km Loop

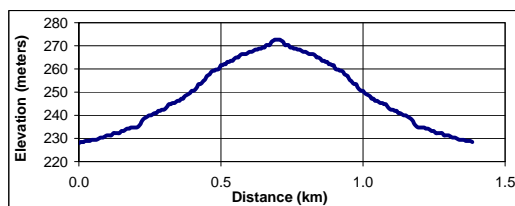

Figure 12: Hill Range Drive Profile, 1.4 km Loop

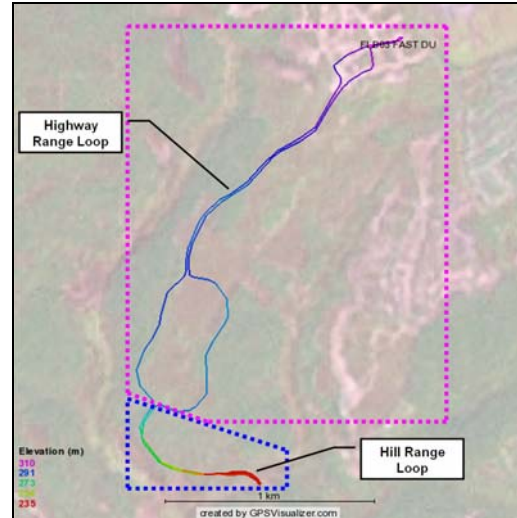

Figure 13: Highway and Hill Range Test Routes (GPSVisualizer)

6 Test Results

The results of the benchmark tests are shown in Table 1. Results indicate dramatic improvements in acceleration performance and hill climb capability. The 0-16 kph and 0-19 kph times both yielded a 38% improvement with the CVP and control system. Additionally, the time to complete the hill climb test was reduced by 20%, and there was a 24% increase in average speed.

The CVP-equipped vehicle was able to reach a top speed of 41.8 kph, which is a 47% increase over the stock vehicle. In reference to the analysis of section 4, this indicates that the stock vehicle is not limited by power at its top speed, but is motor speed-limited.

Table 1. Benchmark Test Results*

	2008 Stock Currie IZIP	2008 NuVinci IZIP	Percent Improvement
ACCELERATION			
0-16 kph (sec)	3.4	2.1	38%
0-19 kph (sec)	4.7	2.9	38%
0.2 km time (sec)	30.0	23.4	22%
MAXIMUM SPEED			
Sustained Speed (kph)	28.4	41.8	47%
HILL CLIMB, 0.46 km			
Time (sec)	141.0	113.4	20%
Average Speed (kph)	18.9	23.5	24%
MAX LOAD UP GIVEN GRADE			
Max Load @ 20% Grade (kg)	77.6	120.7	56%
RANGE			
Highway Range (km)	19.0	18.9	-0.7%
City Range (km)	11.3	13.5	20%
Hill Range (km)	9.3	10.0	7%

* Beta Prototype (FLB03) Data per March 2008

The maximum load up a grade test showed that the *NuVinci* drivetrain increased the load the scooter was able to ascend a grade with by 56%. This is not of trivial importance, as many light electric vehicles disappoint their owners due to the inability to ascend hills while loaded.

The range test results showed that the CVP-equipped vehicle effectively equaled the range of the stock vehicle under the more steady-state highway drive cycle. The *NuVinci* CVP demonstrated significant gains in more dynamic drive cycles that are more typical for commuting LEVs. In the City Range drive cycle, the CVP-equipped vehicle showed a 20% improvement over the stock vehicle. Similarly, a 7% range improvement was attained in the Hill Range drive cycle.

It is notable that the transmission and control system provided substantial performance improvements while also improving the “real world” range of the scooter. Further, the CVP offers a significant increase in top speed with no change to the battery or drive motor.

7 Next Steps

Development is underway to expand the control algorithm to better optimize shift logic and improve the use of efficiency maps of the transmission, motor, and batteries.

Future testing will include isolating the transmission control from the motor control to identify the impact of control algorithms for each component on the overall system performance. At this point the benefits realized are a result of controlling the drive motor and transmission as a system.

Additional analytical models and simulations will be developed to optimize shift curves for input to the control system that will improve acceleration feel and performance.

Further, Fallbrook Technologies Inc. is working with the LEV industry to define test standards for benchmarking these five metrics (acceleration, maximum speed, hill climb, maximum load up a grade, and range) for any vehicle. Continued test procedures are being refined and formalized through consultation with industry leaders to establish a common ground for the developer, and more importantly the consumer, to compare vehicle performance.

8 Conclusion

The application of the *NuVinci* CVP to a typical LEV system offers benefits in acceleration, hill climb, load capacity, top speed, and range. Preliminary analytical models have been developed to characterize the performance of the system equipped with a CVP and test data has confirmed analytical predictions. Substantial improvements in acceleration, hill climb, and top speed were achieved in conjunction with significant range improvements in “real world” dynamic drive cycles. These developments present a major step toward enabling LEVs to become a viable alternative as commuter vehicles.

Continued development is underway to optimize the control system and shift strategy to improve performance among the five metrics, and a standardized test program is being proposed as a common baseline for test validation of LEV systems worldwide.

In addition, a *NuVinci* CVP Developer Kit will be released that will enable manufacturers and vehicle developers to realize these same improvements on their own vehicles. Check the corporate website (www.fallbrooktech.com) for updates, and contact Fallbrook Technologies for availability.

9 Acknowledgments

This paper owes heavily to the foundational analytical and design work by Brad Pohl at Fallbrook Technologies to define a dynamic control simulation of a CVP in an LEV application.

10 References

- [1] INTETS Efficiency Map www.uqm.com/products/specsheets/ accessed on 2-April-2006
- [2] Tempest Power Security Batteries www.tempestbatteries.com accessed on 2-April-2006
- [3] Fallbrook Technologies, Inc. www.fallbrooktech.com, accessed on 2 April 2006.
- [4] Smithson, R., Miller, D., and Allen, D., “Scalability for an Alternative Rolling Traction CVT”, SAE Paper 2004-01-0355, 2004
- [5] Gillespie, T. D., “Fundamentals of Vehicle Dynamics”, Society of Automotive Engineers, Inc. 1992. ISBN 1-56091-199-9.

- [6] Ehsani, M., et. al., “Modern Electric, Hybrid Electric, and Fuel Cell Vehicles: Fundamentals, Theory, and Design,” CRC Press, 2005, ISBN 0-849-3154-4.

11 Authors



Jeremy Carter holds a master’s degree in Mechanical Engineering from Texas A&M University and master’s degree in Technology Commercialization from the University of Texas. His experience includes mechanical system design and program management. He currently manages the Applied Technology group at Fallbrook Technologies.



Loren McDaniel graduated from the Illinois Institute of Technology, Chicago with an master’s degree in Mechanical Engineering and formerly worked as a Product Development Engineer at Fallbrook Technologies Inc. where he helped incorporate variable traction drive transmission technology into various vehicles.



Chris Vasilotis obtained his bachelor’s degree in Mechanical Engineering from Texas A&M University. His experience includes aerospace, automotive, motorcycle, and recreational sports industries. He is the Program Manager for the Electric Vehicle Team at Fallbrook Technologies, helping to develop new applications for the *NuVinci* CVP.